

UFC 4-150-08
01 April 2001



**US Army Corps
of Engineers®**



UNIFIED FACILITIES CRITERIA (UFC)

INSPECTION OF MOORING HARDWARE

U.S. ARMY CORPS OF ENGINEERS

NAVAL FACILITIES ENGINEERING COMMAND (preparing Activity)

AIR FORCE CIVIL ENGINEER SUPPORT AGENCY

**APPROVED FOR PUBLIC RELEASE: DISTRIBUTION
UNLIMITED**

UNIFIED FACILITIES CRITERIA (UFC)
INSPECTION OF MOORING HARDWARE

Any copyrighted material included in this UFC is identified at its point of use. Use of the copyrighted material apart from this UFC must have the permission of the copyright holder.

Record of Changes (changes indicated by \1\ ... /1/)

<u>Change No.</u>	<u>Date</u>	<u>Location</u>
1	19 June 01	pages 3-1, A-1, B-8

This UFC supersedes Military Handbook 1104/3.

ABSTRACT

This handbook is a guide for engineers, planners and facility personnel in scheduling, inspection, maintenance, and repairs of mooring hardware at waterfront facilities and related facilities. Initial chapters provide a summary of responsibilities and policies, field inspection guidelines, and mooring hardware types. Inspection levels, methods, planning, and techniques and checklists are covered for above water inspection. General load capacity testing procedures are described and illustrated for general mooring hardware.

This UFC provides guidance for the specialized inspection and testing of mooring hardware at waterfront facilities and related facilities. Inspection levels, methods, and testing procedures are presented for the mooring hardware. The testing procedures presented herein allot for a more detailed load capacity assessment of specified mooring hardware. The resulting findings of inspections of mooring hardware and fendering are to guide facility personnel in the selection of appropriate analysis, repair and replacement techniques, maintenance, inspection of fieldwork for acceptability, and planning the follow-on inspection requirements.

The standards and methods presented herein are a guide to the planning, inspection, assessment, and reporting of mooring hardware conditions. The standards and methods outlined have been developed from the best technical sources in industry and the military services.

FOREWORD

The Unified Facilities Criteria (UFC) system provides planning, design, construction, operations and maintenance criteria, and applies to all service commands having military construction responsibilities. UFC will be used for all service projects and work for other customers where appropriate.

UFC are living documents and will be periodically reviewed, updated, and made available to users as part of the Services' responsibility for providing technical criteria for military construction. Headquarters, United States Army Corps of Engineers (HQUSACE), Naval Facilities Engineering Command (NAVFAC), and Air Force Civil Engineer Support Agency (AFCESA) are responsible for administration of the UFC system. Technical content of UFC is the responsibility of the preparing tri-service committee. Recommended changes with supporting rationale should be sent to the respective service proponent office, as follows:

- HQUSACE, ATTN: CECW-E, 20 Massachusetts Ave., NW, Washington, DC 20314-1000 or the [Recommended Changes To Engineering Documents](#) page on the TECHINFO site listed below.
- Commander, Atlantic Division, Naval Facilities Engineering Command, 1510 Gilbert Street (ATTN: NAVFAC Criteria Office), Norfolk, Virginia 23511-2699 or ufc@efdlant.navy.mil, by commercial telephone (757) 322-4200 or DSN 262-4200, or by facsimile machine to (757) 322-4416
- Air Force Civil Engineer Support Agency, 139 Barnes Drive, Tyndall Air Force Base, Florida 32403-5319 or larry.spangler@Tyndall.af.mil.

UFC are effective upon issuance. UFC are distributed only in electronic media from the following sources:

- USACE TECHINFO Internet site <http://www.hnd.usace.army.mil/techinfo/index.htm>.
- NAVFAC Criteria Office Internet site <http://criteria.navy.mil/criteria>.
- Construction Criteria Base (CCB) system maintained by the National Institute of Building Sciences at Internet site <http://www.nibs.org/ccb/>.

Hard copies of UFC printed from electronic media should be checked against the current electronic version prior to use to ensure that they are current.

AUTHORIZED BY:

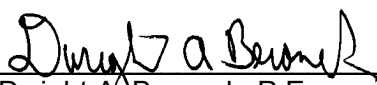
Dwight A. Beranek, P.E.
Chief, Engineering and Construction Division
U.S. Army Corps of Engineers

Dr. Gen Moy, P.E.
Chief Engineer and
Director of Planning and Engineering,
Naval Facilities Engineering Command

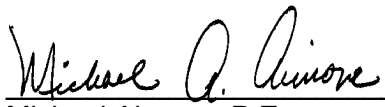
Michael Aimone, P.E.
Deputy Civil Engineer
Deputy Chief of Staff, Installations & Logistics
Department of the Air Force

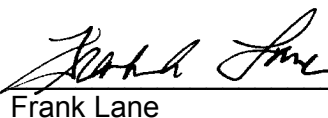
Frank Lane
Director of Analysis & Investment
Deputy Under Secretary of Defense
for Installations
Department of Defense

CONTENTS

	<u>Page</u>
CHAPTER 1 INTRODUCTION	
Paragraph 1-1	SCOPE..... 1-1
1-2	PURPOSE..... 1-1
1-3	APPLICATION..... 1-1
1-3.1	Facilities Covered 1-1
1-3.2	Facilities Not Covered..... 1-1
CHAPTER 2 PLANNING FACILITY INSPECTION	
Paragraph 2-1	MAINTENANCE PLANNING..... 2-1
2-2	PLANNING 2-1
2-2.1	General..... 2-1
2-2.2	Scope of Work 2-1
2-2.3	Existing Data 2-1
2-2.3.1	Drawings..... 2-1
2-2.3.2	Calculations 2-2
2-2.3.3	Existing Reports..... 2-2
2-3	FIELD INSPECTION / DATA GATHERING 2-2
2-3.1	General..... 2-2
2-3.2	Field Inspection..... 2-2
2-3.2.1	Tools Required 2-2
2-3.2.1.1	Hand Tools 2-2
2-3.2.1.2	Equipment 2-3
2-3.2.2	Note Keeping..... 2-3
2-4	ENGINEERING EVALUATION 2-4
2-5	TYPE OF MOORING SERVICE 2-4
CHAPTER 3 QUALIFICATIONS	
3-1	PERSONNEL..... 3-1
CHAPTER 4 INSPECTION FUNDAMENTALS	
4-1	LEVELS OF INSPECTION..... 4-1
4-1.1	Level 1 – Walk Through Inspection 4-1
4-1.2	Level 2 – Visual Inspection 4-1
4-1.3	Level 3 – Detailed Inspection 4-1
4-1.4	Fender System 4-1
4-2	FREQUENCY OF INSPECTION..... 4-1
4-3	INSPECTION METHODS 4-2
4-3.1	Local Conditions 4-2
4-3.1.1	Mooring Hardware Fittings..... 4-2
4-3.2	Fasteners..... 4-2
4-3.3	Supporting Structure..... 4-2
4-3.3.1	Concrete..... 4-2
4-3.3.2	Timber 4-3
4-3.3.3	Steel 4-3

4-3.4	Fender System	4-3
4-3.5	Global Conditions	4-3
4-3.5.1	Pier Structure.....	4-3
4-3.5.2	Structural Analysis	4-3
4-3.5.2.1	Calculations	4-4
4-4	PHOTOGRAPHY	4-4

CHAPTER 5 REPORT

5-1	REPORT PURPOSE AND OBJECTIVES	5-1
5-2	REPORT FORMAT	5-1
5-3	REPORT STRUCTURE.....	5-1
5-3.1	Outline	5-1
5-3.2	Introduction.....	5-1
5-3.3	Activity Description	5-1
5-3.4	Facilities Inspected	5-1
5-3.6	Design Structural Capacity.....	5-2
5-3.7	Existing Conditions	5-2
5-3.8	Appendices.....	5-2
5-3.8.1	Key Personnel	5-2
5-3.8.2	Load Test Procedures.....	5-2
5-3.8.3	Calculations	5-2
5-3.8.4	Mooring Hardware Inspection Records	5-2
5-3.8.5	Deck Fitting Loads Test Reports.....	5-2
5-3.8.6	References	5-2
5-4	3-D MODEL	5-2
5-5	DRAWINGS	5-3
5-6	DATA TABLES	5-3

APPENDIX A	REFERENCES	A-1
-------------------	-------------------------	------------

APPENDIX B	MOORING HARDWARE TESTING	B-1
-------------------	---------------------------------------	------------

FIGURES

<u>Figure</u>	<u>Title</u>	
2-1	Mooring Hardware Inspection Process.....	2-6
2-2	Mooring Hardware Inspection Record	2-7
2-3	Typical Profiles of Mooring Hardware.....	2-8
2-4	Condition Rating Scale for Mooring Hardware	2-9
2-5	Condition Rating Scale for Base Structure	2-10
2-6	Condition Rating Scale for Fender System.....	2-11
5-1	Report Outline	5-4
B-1	Example Deck Fitting Load Test Report.....	B-7

TABLES

<u>Table</u>	<u>Title</u>	
2-1	Commonly Used U.S. Navy Pier Mooring Fittings	2-4
2-2	Mooring Service Types.....	2-5
5-1	Condition of Color Schemes.....	5-3
B-1	Pull Testing Interval Recommendations	B-3

CHAPTER 1. INTRODUCTION

1-1 **SCOPE.** This UFC, 4-105-08, is a guide for the inspection and evaluation of facility berthing capability, for all facilities providing berthing for U.S. Military Ships. It is a source of reference for the planning, inspection and reporting of mooring hardware conditions in a standardized format.

1-2 **PURPOSE.** This handbook provides guidance for the planning, inspection, assessment, and reporting of mooring hardware conditions. It should be used as a tool for helping personnel tasked with maintaining the readiness of shore side facilities for use by the fleet and in support of military marine operations. The Mooring Hardware Report has the following objectives:

- Establish adequacy of mooring facilities.
- Enable facility users to develop efficient berthing plans.
- Establish baseline data on existing mooring hardware and berthing capacity.
- Provide facility users with information sufficient to determine level of effort to maintain or upgrade existing capacity.

1-3 **APPLICATION**

1-3.1 **Facilities Covered.** Types of facilities covered as related to mooring hardware include:

- Berthing facilities (piers, wharves and dolphins) for mooring and for providing support to ships and craft.
- Dry docks used for modification, inspection maintenance and repair of ships.

1-3.2 **Facilities Not Covered.** Facilities not covered in this handbook are:

- Fleet moorings - which are covered in MO-124, *Mooring Maintenance Manual*.
- Mechanical capstans

CHAPTER 2.

PLANNING FACILITY INSPECTION

2-1 **MAINTENANCE PLANNING.** Maintenance planning criteria can be found in UFC 4-150-07 Chapter 2 - MAINTENANCE PLANNING AND TYPES OF FACILITIES for marine structures. Development of a long-term inspection and maintenance program involving all aspects of waterfront facilities is covered in the above document. A long-term inspection program involving regular field inspection of mooring hardware at established intervals should be part of the overall facility maintenance program.

2-2 **PLANNING**

2-2.1 **General.** This section covers the planning required to conduct an inspection and assessment of mooring hardware. Critical aspects of planning an inspection of this nature include the establishment of a clear scope of work and gathering all available data. Figure 2-1 depicts the Mooring Hardware Inspection Process.

2-2.2 **Scope of Work.** Planning the inspection of mooring hardware will begin with the establishment of a scope of work. The scope of work will define the facilities to be inspected and level of inspection. The scope of work should include:

- Number of hardware
- Type of hardware
- Type of support structure
- Level of inspection required
- Date of last inspection
- Fender system type and quantity
- List of ships that normally use hardware, ie., mission critical ships.

2-2.3 **Existing Data.** All available relevant data on the facilities to be inspected and assessed should be gathered at the earliest possible date. This information should be provided to the persons responsible for planning and organizing the inspection and assessment effort such that the level of effort for inspecting a specific facility can be determined. Data and information may be available in many forms as listed below.

2-2.3.1 **Drawings.**

- As-built construction drawings – Original construction drawings will often have vital information regarding mooring and berthing design loads. This information is usually the most accurate data available to the inspector. Caution should be taken to confirm that the data on the plans is accurate and changes to the structure have been investigated and confirmed.
- Repair and maintenance drawings – All modifications to the original structure should be investigated and analyzed as to their impact to the structure.

- Site plans – Site plans can provide layout data and in some cases will have sufficient detail to show mooring hardware position. This data is often out dated and should be confirmed.
- Hydrographic survey plans – Hydrographic data is important to establish depth of water at the berth.

2-2.3.2 **Calculations.** Design calculations to establish the capacity of the supporting structure. Calculations used to determine loads on hardware.

2-2.3.3 **Existing Reports.** Previous inspection reports such as an Underwater Facilities Inspection Report, Prior Mooring Hardware Condition report or Annual Inspection Summaries.

2-3 **FIELD INSPECTION / DATA GATHERING.**

2-3.1 **General.** The purpose of any mooring hardware inspection is to gather information to assess the condition of the mooring hardware system inspected. The level of inspection will determine the amount and type of information gathered. The inspection will focus on gathering the following information:

- Identification of damage
- Confirmation of available data
- Changes in the known supporting structure
- Identification of potential problems with interacting equipment and fixtures.
- Establishing the position of mooring hardware and fenders
- General condition of fender system and hardware
- Gather available background information at the site.

2-3.2 **Field Inspection.** Personnel assigned to conduct a field inspection of mooring hardware should acquire the appropriate tools necessary to accomplish the work. The level of inspection will dictate the required tools. All levels require appropriate record keeping. Information should be recorded in logbooks. The time and level of effort required to conduct an inspection will depend on the amount of background information that is available, level of inspection required, site conditions, site access and activity, as well as the skill of the inspector.

2-3.2.1 **Tools Required.**

2-3.2.1.1 **Hand Tools.** Various hand tools are required to accomplish the task of inspecting mooring hardware. Tape rules, folding rules, measuring wheels, and in some instances surveying equipment will be required to perform tasks such as: dimensioning structural components, finding the position of mooring hardware, and measuring distress within the structural system. Other tools such as wire brushes, chipping hammers, and scrapers can be used to clean and uncover structural components that are not readily visible. Marking devices such as paint stick, keel, paint and ink pens can be used to establish identifying marks on each hardware unit for reference.

2-3.2.1.2 **Equipment.** Heavy equipment may be required to conduct Level 3 Inspections. Equipment such as diving gear, compressions, jacks, hoists, rigging, load cells, and cranes should be used as necessary to accomplish the work.

2-3.2.2 **Note Keeping.** Field inspection data and notes should be kept in a surveyor's field book or the Mooring Hardware Inspection Sheet (see Figure 2-2) and in an orderly and legible fashion. Photographic documentation of each piece or representative piece of mooring hardware should be taken and recorded in the field book. Notes can be kept in tabular form within the notebook. The following minimum data is required:

- Hardware number or designation – Each fitting should have a unique alphanumeric designation. If an existing system is in place it should be used. If there is no system for identifying hardware, unique designations should be assigned. For example, identifying systems such as "B1-C3" for Berth 1, Cleat Number 3 can be used.
- Size and type of hardware – Record the casting number or serial number that identifies each type of hardware. Standard U.S. Navy fittings can be found in Table 2-1 and Fig. 2-3. If the hardware number cannot be found or identified in the field then the overall dimensions should be recorded.

Additional information concerning the sizes and working capacities of pier and wharf mooring fittings is found in MIL-HDBK-1025/1.

- Position of hardware (x,y,z coordinates) – A coordinate system should be identified and established such that the location of each hardware can be established along the berth. The relationship between the hardware and the tidal datum should also be established.
- Reference position of coordinates – All coordinate systems should be referenced to a local system for each facility i.e. reference benchmark on site, or activity base map coordinates.
- Condition of the hardware – The condition of each piece of mooring hardware should be rated in the field. The rating system should be on a scale of 1 to 4, as described in Fig. 2-4.
- Condition of the base structure – The base structure of each piece of hardware should be rated on a scale of 1 to 4, as described in Fig.2-5
- Condition of the fender system should be noted and rated on a scale of 1 to 4, as described in Fig. 2-6.
- Fasteners – The number, pattern and size of the fasteners on each piece of mooring hardware should be recorded.
- Additional remarks – Additional notes such as odd conditions, qualifying remarks, and other information that might be deemed useful should be recorded.
- Photo roll and number

- All sketches and other ancillary notes should be kept in the same notebook.

Table 2-1. Commonly Used U.S. Navy Pier Mooring Fittings

DESCRIPTI ON	SIZE	HEIGHT	BOLTS	WORKING CAPACITY	Horz
		BASE			@45°
					Nom
SPECIAL MOORING BOLLARD "A"	1200 mm (48 in)		300 x 25 mm dia. (12 x 1-in) dia.	2936 kN (660 kips) 1913 kN (430 kips) 2002 kN (450 kips)	
	1200 x 1200 mm (48x48 in)				
SPECIAL MOORING BOLLARD "B"	1112.5 mm (44.5 in)		200 x 68.75 mm dia. (8 x 2.75-in dia)	1201 kN (270 kips) 961 kN (216 kips) 890 kN (200 kips)	
	975 x 975 mm (39x39 in)				
LARGE BOLLARD WITH HORN	1112.5 mm (44.5 in)		100 x 43.75 mm (4 x 1.75-in dia)	463 kN (104 kips) 294 kN (66 kips) 311 kN (70 kips)	
	975 x 975 mm (39x39 in)				
LARGE DOUBLE BITT WITH LIP	650 mm (26 in)		250 x 43.75 mm (10 x 1.75-in dia)	Nom = 334 kN (75* kips)	
	1837.5 x 700 mm (73.5x28 in)				
LOW DOUBLE BITT WITH LIP	450 mm (18 in)		250 x 40.625 mm (10 x 1.625-in dia)	Nom = 267 kN (60* kips)	
	1437.5 x 537.5 mm (57.5x21.5 in)				
42-INCH CLEAT	325 mm (13 in)		150 x 28.125 mm (6 x 1.125-in dia)	Nom = 178 kN (40 kips)	
	650 x 356.25 mm (26x14.25 in)				
30-INCH CLEAT	325 mm (13 in)		100 x 28.125 mm (4 x 1.125-in dia)	Nom = 89 kN (20 kips)	
	400 x 400 mm (16x16 in)				

*Working capacity per barrel; after NAVFAC Drawing No. 1404464

2-4 **ENGINEERING EVALUATION.** An evaluation of the data can only be conducted once the inspection is complete. The field data as well as the existing data will be reviewed and analyzed to formulate allowable load criteria.

2-5 **TYPE OF MOORING SERVICE.** The type of mooring service should be considered when planning the inspection frequency. For example, Berths with Mooring

Service Type III should be considered high priority as ships moored at these berths may not have the ability to get under way in case of an approaching storm. See Table 2-2 for an explanation of mooring service types.

Table 2-2. Mooring Service Types

MOORING SERVICE TYPE	DESCRIPTION
TYPE I	This category covers moorings that are used in winds of less than 34 knots and currents less than 2 knots. Moorings include ammunition facilities, fueling facilities, deperming facilities, and ports of call. Use of these moorings is normally selected concomitant with forecasted weather.
TYPE II	This category covers moorings that for general purpose berthing by a vessel that will leave prior to an approaching tropical hurricane, typhoon, or flood.
TYPE III	This category covers moorings that are used for up to 2 years by a vessel that will not leave prior to an approaching tropical hurricane or typhoon. Moorings include fitting-out, repair, drydocking, and overhaul berthing facilities. Ships experience this service approximately every 5 years. Facilities providing this service are nearly always occupied.
TYPE IV	This category covers moorings that are used for 2 years or more by a vessel that will not leave in case of a hurricane, typhoon, or flood. Moorings include inactive, drydock, ship museum, and training berthing facilities.

Figure 2-1. Mooring Hardware Inspection Process

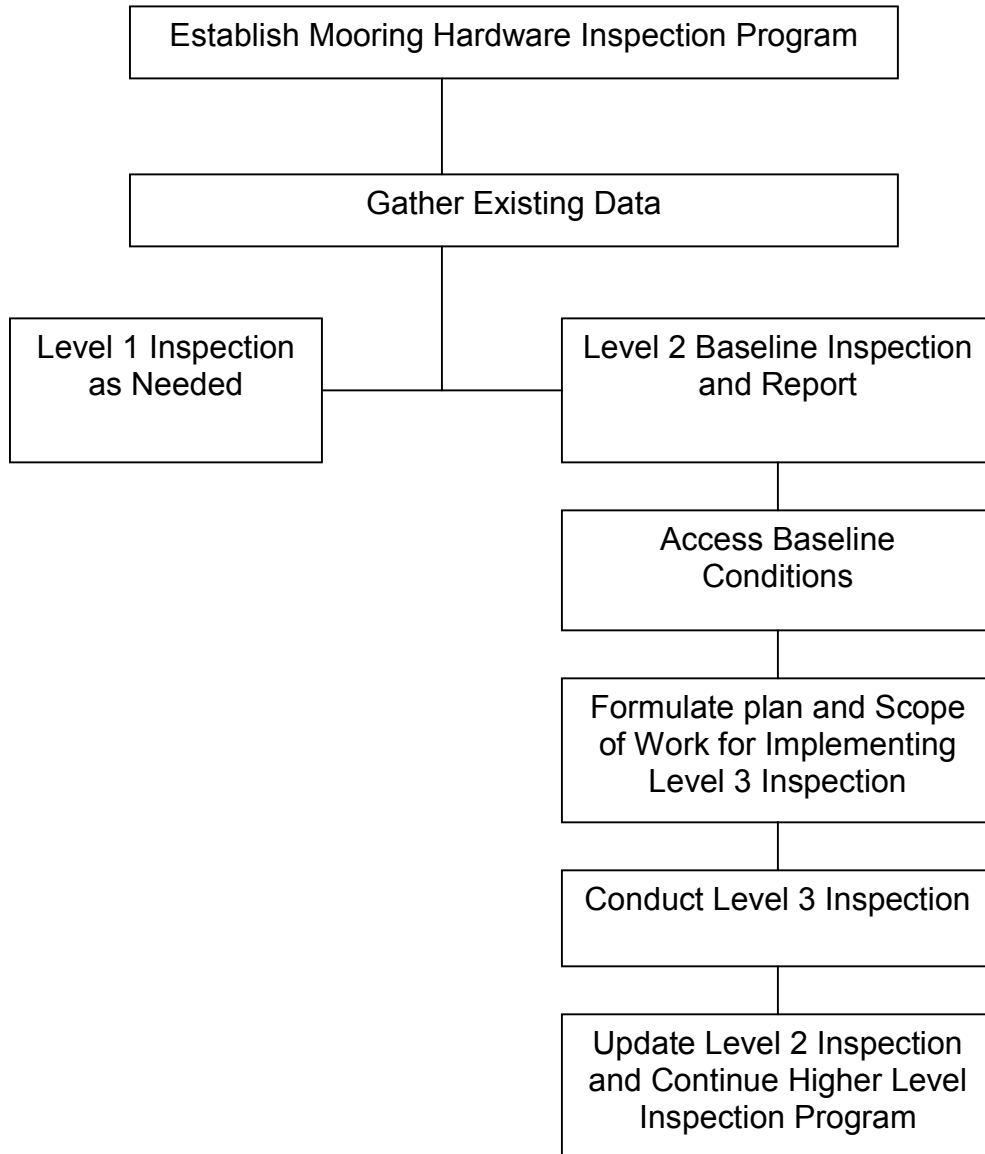

Figure 2-3 Typical Profiles of Mooring Hardware

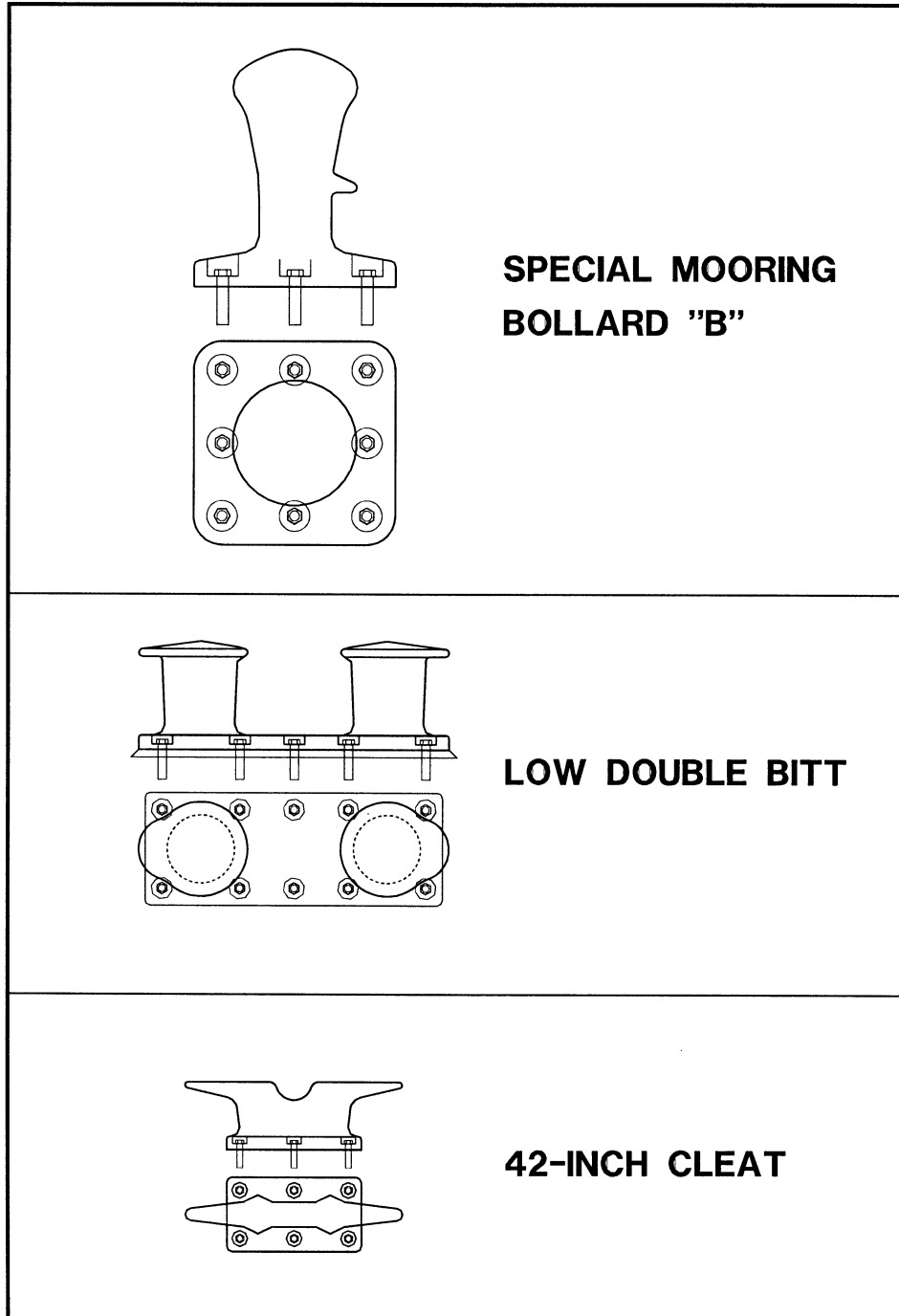
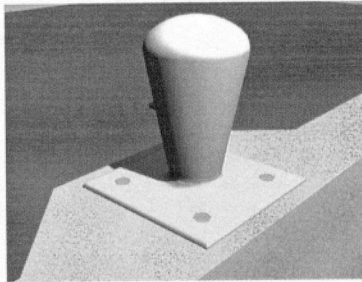

Figure 2-4 Condition Rating Scale for Mooring Hardware

Example of Condition

Mooring Hardware Condition Rating



- #1 No Defects
- New coating (minor blemishes and corrosion on less than 10% of surface area)
 - No wear marks
 - No visible corrosion of fasteners
 - Bolt countersinks sealed

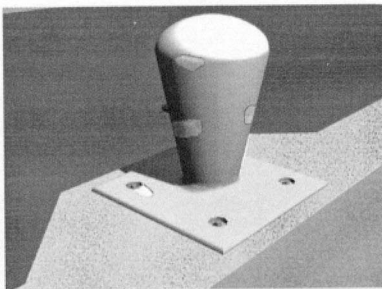

- #2 Minor Defects
- Minor surface corrosion (10% to 25% of surface area)
 - Minor wear marks on fitting surface less than 3.125 mm (.0125 inches) deep
 - Minor corrosion of fasteners

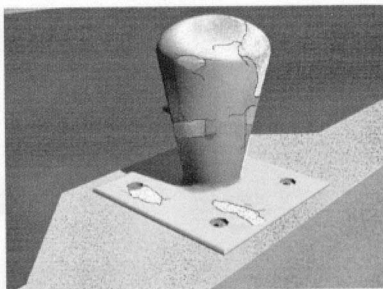

- #3 Moderate Defects
- Heavy corrosion with loose scale (greater than 25%)
 - Noticeable corrosion of fasteners
 - Significant surface wear marks up to 7.8125 mm (0.3125 inches) deep

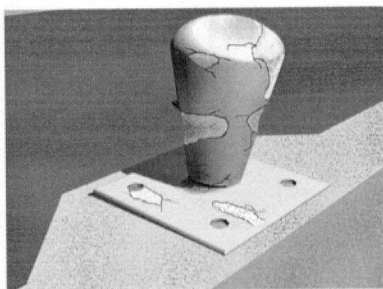

- #4 Sever Defects
- Severe corrosion, heavy scale, noticeable surface pitting and 25% or greater loss of area at critical section
 - Displaced or rotates fitting
 - Broken or cracked fitting components
 - Noticeable corrosion and section loss of fasteners
 - Loose fasteners

Figure 2-5 Condition Rating Scale for Base Structure

Example of Condition

Mooring Support Structure Condition Rating

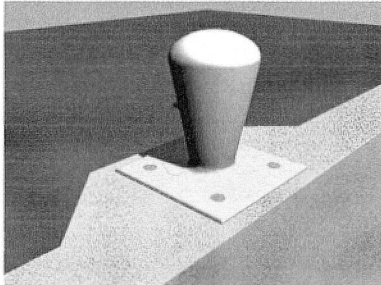

- #1 No Defects
- Surface clean and smooth
 - No cracking
 - No noticeable deterioration

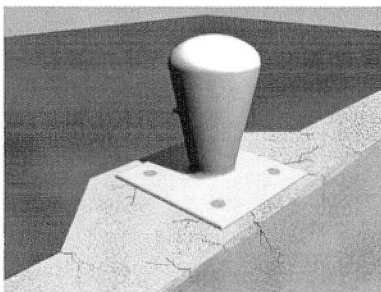

- #2 minor Defects
- Weathering of concrete and wood
 - Minor corrosion of steel (no significant section loss)
 - Hairline cracking of concrete due to thermal expansion and/or age

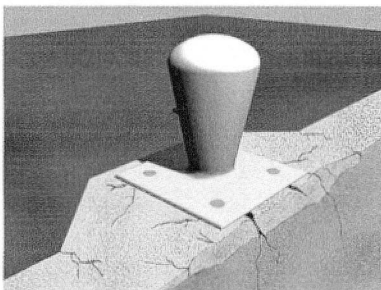

- #3 Moderate Defects
- Noticeable cracking of concrete due to age
 - Corrosion of steel with section loss
 - Timber cracked and checked, weathered, susceptible to dry rot

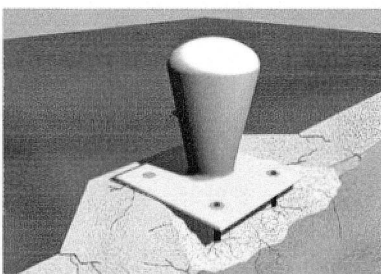

- #4 Severe Defects
- Cracking or spalling as a result of overload under hardware base
 - Dry rot on timber members
 - Significant corrosion of steel members
 - Displacement or yielding of any supporting members
 - Loss of full bearing under hardware

Figure 2-6 Condition Rating Scale for Fender System

Example of Condition

Fender Systems Condition Rating

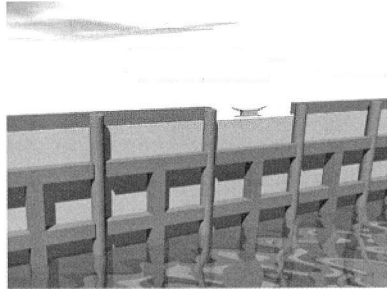

- #1 No Defects
- In perfect condition

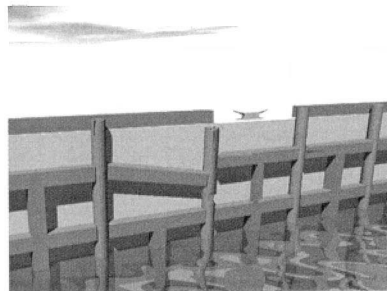

- #2 Minor Defects
- Weathering of timber
 - Minor damage on piles and wales
 - Minor corrosion of bolts (no significant loss of section)
 - Minor wear on steel and rubber components

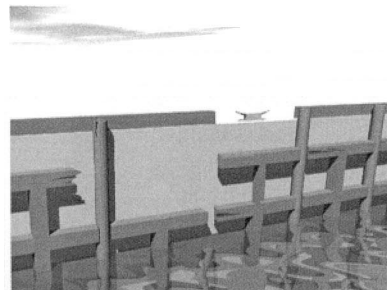

- #3 Moderate Defects
- Noticeable cracking of concrete due to age
 - Corrosion of steel with section loss
 - Timber cracked and checked, weathered, susceptible to dry rot
 - Rubber components have minor tears and/or gouges

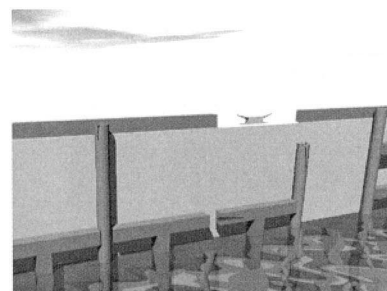

- #4 Severe Defects
- Many members displaced or missing
 - Dry rot on timber members
 - Significant corrosion of bolts
 - Displacement or yielding of any supporting members
 - Non-functional rubber components with significant tears and displacement

CHAPTER 3.
QUALIFICATIONS

3-1 **PERSONNEL.** If a contract is used, the inspection of mooring hardware should be conducted under the supervision of a Registered Professional Engineer (P.E.) who has experience in the design and inspection of marine structures. At a minimum the supervising engineer (P.E.) should be onsite and involved in the inspection to assess and record conditions encountered using standard engineering practice. Level 1 inspections may be conducted by technicians under the supervision of a registered professional engineer. For level 2 or level 3 inspections, which may require underwater inspection as well as the operation of equipment, personnel should be fully qualified and should have adequate levels of support to accomplish the task. \1\ All work operations shall be accomplished in accordance with the standards identified in Appendix A. /1/ Guidance for underwater inspections can be found in \1\ UFC 4-150-07, *Maintenance of Waterfront Facilities*. /1/

CHAPTER 4. INSPECTION FUNDAMENTALS

4-1 LEVELS OF INSPECTION.

4-1.1 **Level 1 - Walk through Inspection.** This inspection is a walk through inspection to assess damage following a storm event and to confirm any changed conditions. Gross deficiencies can be identified during this inspection. This level of inspection cannot provide sufficient data to assess the capabilities of a mooring system.

4-1.2 **Level 2 - Visual Inspection.** This inspection will involve visual observation of the condition of exposed components of the mooring hardware and supporting structure. The hardware should be visually inspected for cracks or other anomalies. Hardware geometry should also be inspected to determine if displacement has occurred. Bolts, if exposed, can be inspected to determine their relative tightness. The general condition of the supporting base structure should be inspected for anomalies such as cracking and/or displacement. Under this level of inspection the position of the hardware should be determined. The relative position in relation to the three principal axis coordinates (x,y,z) should be established to the nearest foot. The Level 2 visual inspection is required to establish baseline conditions.

4-1.3 **Level 3- Detailed Inspection.** This inspection is performed in addition to the inspection tasks performed under the Level 1 and Level 2 inspections. A detailed inspection will involve the observation of exposed components of the supporting structure such as the underside of the pier deck and piles.

In addition, a detailed inspection may involve partly destructive techniques related to dismantling and load testing mooring hardware. Removal of sealing material and fasteners for inspection and load testing will be accomplished as directed by the Scope of Work under this level of inspection. Individual fasteners may be load tested in tension by using a jacking apparatus. The entire hardware piece may be load tested using various methods. The method employed for load testing of hardware will be dependent upon the type of hardware piece and site conditions. Guidelines for load testing hardware and fasteners can be found in Appendix B of this document.

4-1.4 **Fender System.** A Level 1 visual inspection of the fender system should be conducted concurrently with all levels of mooring hardware inspection. Refer to NAVFAC MO-104.1 for fender system inspection. The type of fender system will be noted and the general configuration will be established as it relates to the mooring hardware. Size and location of fender system components will be noted to determine the placement of ships.

4-2 **FREQUENCY OF INSPECTION.** Under most circumstances all mooring hardware should receive a Level 1 Inspection annually, Level 2 Inspection every 5 years. The type of structure and the class of service will also dictate the inspection frequency and level of inspection. For timber structures that are susceptible to impact and severe environmental conditions the frequency of Level 2 inspections should be set at every 3 years. For structures that are high priority, the berthing officer will determine the level of inspection. In instances where extreme storm events have resulted in the potential overloading of mooring hardware, a Level 1 inspection should be conducted to determine post storm conditions. Level 3 Inspections involving load testing should be

conducted as directed by the Berthing Officer or as described in Appendix B, based on hardware priority level.

4-3 **INSPECTION METHODS.**

4-3.1 **Local Conditions.**

4-3.1.1 **Mooring Hardware Fittings.** Each piece of mooring hardware should be visually inspected for anomalies. Conditions that are commonly found include cracks, abrasion (due to wire rope), corrosion and displacement. Cracks are usually the result of impact loading or overloading the hardware under extreme conditions. Abrasion normally occurs when mooring lines are pulled around the hardware causing friction and erosion of the casting under the barrel or horn. If this condition is severe, it will weaken the casting through loss of cross sectional area. Documentation of the depth of erosion, location, and area are required to establish loss of strength. The condition of the coating should be noted. Coatings that have mechanical damage, i.e., cracks, peeling, or abrasion, should be described. Coating systems that have failed or are worn out should also be described, as well as any resulting corrosion. Levels of corrosion can be described as rust stains, light scale, and heavy scale. The surface roughness of the steel should also be described. Corrosion of the casting should be assessed to determine the loss of section at critical points on the casting. Heavy corrosion will also affect the surface roughness of the hardware increasing the chafing and wearing of mooring lines. Observations of the mooring hardware plumb and level are made to determine prior overloading and failure of the surrounding soil or fasteners.

4-3.2 **Fasteners.** Fasteners consisting of steel bolts are used to anchor the mooring hardware to the supporting structure. In some cases mooring hardware is embedded directly in the supporting structure. Where fasteners are used, their function within the mooring system is critical and is almost always the critical structural element. Fasteners are generally inaccessible as a result of typical mooring hardware details calling for protection usually in the form of lead fill, bituminous fill or grout being placed in the bolt pockets. If the fasteners are not visible, then a Level 1 or 2 inspection will result in minimal fastener data. A Level 3 inspection is required to determine the condition of the fasteners. For newer structures, the fasteners may pass through blocking and terminate with nuts and washers bearing on heavy plates. This part of the structure is accessible and should be inspected for loss of section due to corrosion. If fasteners are embedded in the structure and the bolt pockets are filled, the only inspection technique available to the inspector is to remove the casting and observe the fastener for corrosion and loss of cross sectional area. Load testing of the fasteners can be conducted without removal of the casting and will result in the determination of an allowable load. See Appendix B for load testing criteria.

4-3.3 **Supporting Structure.**

4-3.3.1 **Concrete.** The majority of heavy load mooring hardware is attached to concrete decks. Concrete acts well to resist the forces applied by mooring hardware. The compressive strength of concrete resists the shear forces generated as well as providing excellent distribution of load through the structure. Factors to consider when inspecting concrete that supports mooring hardware include cracking, disintegration and corrosion of reinforcing steel. Cracking occurs in all concrete through many processes both as a result of natural factors and from outside forces such as impact. The inspector

must be able to determine the differences between the various types of cracks, their causes and the structural implications of those cracks. Cracks of a concerning nature include: shear cracks near the edge of the pier deck (running at 45 degrees through the corner); diagonal cracking on the deck surface running at 45 degrees from the hardware to the edge; and radial cracking around fasteners indicating cone failure. Gaps at the hardware base or crushing of bedding grout indicate movement or overloading and should be noted. General deterioration of the concrete should be observed and noted. The mooring hardware should be founded on a solid concrete matrix and/or bedded in grout to provide full contact on the bottom and sides. The concrete should be solid and not exhibit any significant disintegration or spalling.

4-3.3.2 **Timber.** Timber structures should be inspected for structural failures such as: crushing of the timber under the hardware or the fastener bearing plates, cracking or failed members, and displaced members. Timber also exhibits deterioration in several forms such as: dry rot, marine borers, termites or other insects. These conditions should be noted and assessed based on their impact to the structure and mooring hardware.

4-3.3.3 **Steel.** Steel supporting structures exhibit conditions such as corrosion, buckling, and cracking. Steel members are generally fastened with either bolts or welds. Bolts should be inspected for tightness, loss of cross sectional area due to corrosion, and bearing. Welds should be inspected visually for cracking.

4-3.4 **Fender System.** Visual observation of the fender system should be made in sufficient detail to establish the typical cross-section and to detail the energy absorbing characteristics of the system. Where timber fender systems are employed the general condition of the timber components should be noted in terms of berthing capability. Where other types of fender systems are in place, the over all capacity of the system should be documented. Locations where damage has occurred should be noted. Missing fender units should be noted and identified.

4-3.5 **Global Conditions.** Global conditions refer to the condition of the supporting pier, wharf or dolphin structure. The inspection of these structures is closely related to the condition of the mooring hardware with respect to the capacity of the mooring system. For example, the sum of the capacities of the mooring hardware may exceed the total capacity of the structure to resist these loads. In this case the mooring hardware cannot be fully developed. Berthing plans are required to factor these limitations into the allowable berthing capacity for the facility. Inspection of pier facilities is addressed in UFC 4-150-07, *Maintenance of Waterfront Facilities*.

4-3.5.1 **Pier Structure.** The significant loading imposed on the pier structure by mooring hardware is in the lateral direction (horizontal "x" direction), which in most cases is resisted by batter piles or passive earth pressure. Piers vary in their construction and the methods employed to transmit these loads to the soil. Open pier structures generally have battered piles (piles at an angle) along with plumb piles (vertical piles,) as well as significant dead loads to resist the lateral and resulting uplift loads. Solid pier structures rely on their massive dead load for stability, as in cellular structures or in the resistance of deadman in the case of tied back sheet pile bulkheads.

4-3.5.2 **Structural Analysis.** The inspecting engineer should collect all available data to ascertain the capacity of the pier structure to resist lateral loads. Available information may include:

- Original design drawings and calculations
- Modifications to the structure
- Previous inspection reports

4-3.5.2.1 **Calculations.** When directed, a licensed professional engineer should calculate the lateral capacity of the facility based on available data and according to MIL-HDBK 1026/4, *Handbook for Mooring Design*. The NAVFAC software, *Waterfront Analysis Toolbox for Engineers (WATERS)* provides electronic tools to assist in the analysis. For each ship that uses the facility, the analysis should provide the maximum wind speed for safe mooring. Caution should be exercised in using appropriate factors of safety based on the accuracy and scope of available data.

4-4 **PHOTOGRAPHY.** Photography should be used to document the condition of each piece of hardware. This can be used in future assessments to determine the change in conditions. Photographs should include a general overview of the hardware piece and any significant conditions. The hardware should be identified within the photograph. An overview of each berth showing the fender system should be taken and included within the report.

CHAPTER 5 REPORT

5-1 **REPORT PURPOSE AND OBJECTIVES.** The mooring hardware report should present the data acquired during the field investigation and the results of the analysis of that data for the use by berthing officers in the formulation of berthing plans, scheduling repairs and instituting a mooring hardware load test program.

5-2 **REPORT FORMAT.** For consistency, all reports should follow the Report Outline in Figure 5-1. The contents of each section are described below. Each report should be submitted in MS Word (.DOC), Adobe Acrobat (.PDF) and .html formats. The quantity of each submittal should be determined in the scope of work. The digital files should be submitted on CD-ROM media.

5-3 **REPORT STRUCTURE**

5-3.1 **Outline.** See Figure 5-1.

5-3.2 **Introduction.** This section is largely a descriptive overview with sections including:

- 1.1 Background/Objectives
- 1.2 Report Description
- 1.3 Condition Rating
- 1.4 Digital Model.

5-3.3 **Activity Description.** This section has subsections including:

- 2.1 Location
- 2.2 Existing Waterfront Facilities along with regional, area, and facility maps that are the same as in the Underwater Facilities Inspection Report.

Additional subsections include:

- 2.3 Inspection Procedure and
- 2.4 Hardware Numbering System.

In these subsections, the inspection procedure and hardware numbering system are explained in detail to the reader. In the inspection procedure subsection, the condition rating system is described as well as the method of locating the position of the mooring hardware. This will provide the reader with an understanding of the level of accuracy of the inspection and data. The subsection on the Hardware Numbering System with an understanding of the system used and why this particular system was employed, i.e., whether the system was in place or developed for this particular inspection.

5-3.4 **Facilities Inspected.** This section constitutes the body of the report and has the following subsections:

- 3.1.1 Description

- 3.1.2 Design Structural Capacity
- 3.1.3 Existing Condition

5-3.5 **Facilities Description.** Includes a summary of the history of the facility structure including the date of original construction, type of structure, length of berth, deck elevation, depth of water (MLL datum) and a description of the fender system. The intent of this section is to give the reader a solid background on the particulars of the structure while being concise. In addition to structure description, the current use of the facility should also be described. The vessel complement as well as the type of service (I, II, III, or IV) should be noted. See MIL-HDBK-1026/4, *Handbook for Mooring Design*.

5-3.6 **Design Structural Capacity.** This section consists of a table reviewing mooring hardware data associated with the facility. The data within this table includes: mooring hardware type and quantity, design load rating of the hardware, the calculated load capacity of the hardware if manufacturers data is not available, and the design and/or calculated capacity of the base structure. This table is a structural summary intended to provide the reader with information required to determine berthing capacity.

5-3.7 **Existing Condition.** This section provides a summary of the conditions found during the inspection. A discussion of hardware rated at #3 or #4 is included to highlight conditions that warrant attention. Following the existing condition text, are photo pages that present a photographic example of each type of hardware found on the facility and photos of anomalous conditions. Following the photo page(s) is the figure showing the 3-D perspective view of the facility (when requested). Following this is the figure (drawing) showing the plan view of the facility with the condition of the fittings and fender system noted. Following this is the data table. The data table has all the information available about each piece of mooring hardware. This information includes; hardware #, node #, x COORD., y COORD., z COORD, type of hardware, line pull rating, and the condition of both the hardware and it's support structure.

5-3.8 **Appendices.**

5-3.8.1 **Key Personnel.** Each report should have a list of key personnel responsible for organizing, conducting, and implementing the investigation.

5-3.8.2 **Load Test Procedures.** This section will include a description of any load testing undertaken. The level of testing, quantity and location of load tests will be described. (See Appendix B.)

5-3.8.3 **Calculations.** All calculations to determine the load capacity of mooring hardware and/or supporting structures is presented in this appendix.

5-3.8.4 **Mooring Hardware Inspection Records.** The actual mooring hardware inspection records should be included in this section.

5-3.8.5 **Deck Fitting Load Test Reports.** The load testing reports should be presented in this section.

5-3.8.6 **References.** All references used in the body of the report should be identified in this section.

5-4 **3-D MODEL.** A three dimensional model of each facility will be generated when requested for Level 2 inspections in AutoCAD Release 14 or greater to assist

facility users in the placement of ships and camels along the pier or wharf in conjunction with fender systems that are in place. At a minimum the model should include: all mooring hardware, main components of the permanent fender system, mudline representation, water level representation, and all fixtures and buildings within 50 feet of the berth face or that would cause obstruction to berthing lines. A perspective view of the berth should be presented in the body of the report for each facility in the form of a figure in 8.5" x 11" format.

5-5 **DRAWINGS.** The report will include plan views of each berth showing the location of each mooring hardware piece with the hardware identification number as well as its condition. The condition of the hardware should be color coded to match the color-coding of the data tables. The condition of the fender system should also be noted with a color line running parallel to the face of the berth. The plans will be to scale such that laying out mooring lines can be planned and facilitated.

Obstructions to mooring lines will also be shown on the plan. The north arrow and direction of current ebb and flood will also be shown.

5-6 **DATA TABLES.** Data tables will be included in the report and in spreadsheet format. At a minimum the data tables will include: x, y, z coordinates of each piece of hardware, its identification number, its node number, the condition of the hardware and its base, the type of hardware, and its allowable line pull rating. The hardware condition will be annotated both numerically and in color as noted in Table 5-1. The data table will be produced in Excel format as shown and should have the ability to be manipulated in to the EMOOR database (see MIL-HDBK-1026/4, *Handbook for Mooring Designs*.) The node number, coordinates and the line pull should be numbers (not labels) to facilitate import into a database in Excel format.

Table 5-1. Condition of Color Schemes

Condition Color Level	Color	AutoCAD 2000 Color Number
1 = Excellent	Green	90
2 = Satisfactory	Blue	160
3 = Marginal	Yellow	40
4 = Poor	Red	240

Figure 5-1. Report Outline

- Report Cover
- Title Page
- Executive Summary
- Table of Contents
- List of Figures
- List of Photographs
- List of Tables and Data
- Section 1.0 Introduction
 - 1.1 Background/Objectives
 - 1.2 Report Description
 - 1.3 Condition Rating
 - 1.4 Digital Model
- Section 2.0 Activity Description
 - 2.1 Location
 - 2.2 Existing Waterfront Facilities
 - 2.3 Inspection Procedure
 - 2.4 Hardware Numbering System
- Section 3.0 Facilities Inspected
 - 3.1 Facility No. 1
 - 3.1.1 Description
 - 3.1.2 Design Structural Capacity
 - 3.1.3 Existing Condition
 - 3.2 Repeat as necessary
- Appendices
 - A. Key Personal
 - B. Load Test Procedures
 - C. Calculations
 - D. Mooring Hardware inspection Records
 - E. Deck Fitting Load Test Reports
 - F. References

APPENDIX A

REFERENCES

NAVFAC PUBLICATIONS

Atlantic Division
Naval Facilities Engineering Command
1510 Gilbert Street
Norfolk, VA 23511-2699

<http://criteria.navfac.navy.mil/criteria/>

MIL-HDBK 1025/1, (1987) Piers and Wharves

MIL-HDBK 1026/4, (1999) Handbook for Mooring Design

\1\ UFC 4-150-07 /1/, (2001) Maintenance of Waterfront Facilities

MO 104.1, (1990) Maintenance of Fender Systems and Camels

MO 124, (1987) Mooring Maintenance Manual

\1\ NAVFAC P-300, Management of Civil Engineering Support Equipment /1/

\1\ NAVFAC P-307, Management of Weight Handling Equipment /1/

\1\ NAVFACINST 5100.11J, NAVFAC Safety and Health Program /1/

U.S. Army Corps of Engineers
www.hdn.usace.army.mil/techinfo/index.asp

National Archives and Records Administration
www.access.gpo.gov/ara/cfr/index.html

\1\ EM-385-1-1, Safety and Health Requirements Manual /1/

\1\ Occupational Safety and Health Standards, Code of Federal Regulations /1/

NAVFAC SOFTWARE

Atlantic Division
Naval Facilities Engineering Command
1510 Gilbert St.
Norfolk, VA 23511-2699

Waterfront Analysis Toolbox for Engineers (WATERS)

NON-GOVERNMENT PUBLICATIONS

American Society for Testing and Materials (ASTM)
100 Barr Harbor Drive
West Conshohocken, PA 19428-2959

E 488, (1996) Standard Test Methods for Strength of Anchors in Concrete and Masonry Elements.

www.astm.org

American Society for Quality, (ASQ)
P.O. Box 3005
611 E. Wisconsin Ave.
Milwaukee, WI 53201-3005

ASQ Z1.4, (1993) Sampling
Procedures and Tables for Inspection
by Attributes

ASQ Z1.4, (1993) Sampling
Procedures and Tables for Inspection
by Variables for Percent
Nonconforming

APPENDIX B

MOORING HARDWARE TESTING

SECTION 1. INTRODUCTON

1-1 Scope. This Appendix is a guide for the testing of mooring hardware at waterfront facilities. It is a source of reference for the planning, testing and reporting of current load capacities of mooring hardware at waterfront facilities in a standard format.

1-2 Purpose. This Appendix provides guidance for the planning, testing and reporting of current mooring hardware load capacities. It should be used as a tool for assisting personnel tasked with maintaining the readiness of shoreside facilities for use by the fleet and in support of military marine operations.

The objectives of the Mooring Hardware Report are:

- To establish adequacy of mooring facilities
- Enable facility users to develop efficient berthing plans
- Establish baseline data on existing mooring hardware and berthing capacity
- Provide facility users with information sufficient to determine the level of effort necessary to maintain or upgrade existing capacity,

This handbook covers berthing facilities for mooring and providing support to ships and craft, as well as dry docks used for modification, inspection, maintenance and repair of ships.

This handbook does not cover fleet moorings (covered in MIL-HDBK-1026/4, *Handbook for Mooring Design*) or mechanical capstans.

SECTION 2. PLANNING HARDWARE TESTING PROGRAM

2-1 General Description. This section covers the planning required to conduct the testing of mooring hardware. Critical aspects of planning testing of this nature include the establishment of a clear scope of work and gathering all available data as well as understanding the prioritization of berths and fittings.

2-2 Scope of Work. Planning the testing of mooring hardware will begin with the establishment of a scope of work. The scope of work will define the mooring hardware to be tested and the level of testing to be conducted. The scope of work should be made following initial findings of the Level 2 Baseline Inspection and Report (see MO 104.1, *Maintenance of Fender Systems and Camels*). The scope of work should include:

- Hardware to be tested, by established designation.
- Type of hardware.
- Type of support structure.
- Level of testing required.
- Accessibility.

- Date of last inspection/testing.

2-3 Existing Data. All available relevant data on the mooring hardware to be tested should be gathered at the earliest possible date. This information should be provided to the persons responsible for planning and organizing the testing effort such that the level of effort for testing a specific piece of hardware can be determined. Data and information may be available in many forms as list below:

- Mooring Hardware Inspection report
- Design Plans
- Berth priority Ratings
- Hardware priority ratings

2-4 Site Conditions. The portion of the waterfront facility surrounding the mooring hardware to be tested should be evaluated for accessibility. If there are no limitations to accessibility of the mooring hardware, all options for testing should be considered. This information assists in formulating accurate cost estimates for the testing.

2-5 Testing Plan. Testing of fittings is relatively expensive and time consuming, so use periodic testing using a statistical basis. Prioritize the tests based on the importance of the mooring facility.

Various levels of testing can be instituted to achieve the desired results. For example, if it is determined that the required level of accuracy is 100%, then all fittings will need to be tested. If 95% accuracy is required, then the number of tests can be reduced significantly. The sampling criteria can be based on statistical sampling techniques. Statistical sampling provides an objective method for determining sample size for a desired confidence level and precision. The result of a statistical sampling program would determine the approximate number of fittings that are marginal or unacceptable; however, it would not be able to determine the location of those fittings. An estimation of the load carrying capacity and condition of the fittings in general could be made. Testing of every fitting would be required for 100% accuracy. A statistical approach may be a reasonable cost effective method of initiating a testing program that would determine the overall adequacy of the berthing system.

Standard sampling plans are presented in ASQ Z1.9, *Sampling Procedures and Tables for Inspection of Variables for Percent Nonconforming* or ASQ Z1.4, *Sampling Procedures and Tables for Inspection by Attributes* based on choice of inspection methods; inspection by variables or by attributes. ASQ Z1.4 may be well suited for a testing program where the fittings are either passing or failing the load test.

2-6 Facility Prioritization. Review mooring facilities and prioritize each mooring hardware unit as 'HIGH', 'MEDIUM' or 'LOW' to determine the extent of testing required. Consider the following factors in assigning testing priorities.

- Visual inspections may find possible problems and indicate that certain mooring fittings need to be assigned highest priority.

- Berths providing Mooring Service Type III are especially high priority, because the ships under repair at these piers and wharves cannot get under way in case of an approaching storm.
- High capacity fittings secure a larger portion of a mooring load at a given facility, and should be assigned higher priority (i.e. a Special Mooring Bollard 'A' holds more load than a 30-inch cleat, so the bollard is assigned a higher priority).
- Older facilities not previously pull tested are more likely to suffer from structural deterioration and should be assigned higher priority. Testing recommendations are shown in Table B-1.

Table B-1. Pull Testing Interval Recommendations

HARDWARE PRIORITY	TESTING INTERVAL	MINIMUM % OF HARDWARE	DESCRIPTION
HIGH	12 years	20%	For older and very important facilities, up to 100% of fittings can be tested. If any of the tested fittings fail, then testing should be expanded to include a higher percentage of fittings.
MEDIUM	18 years	10%	For older or very important facilities, up to 50% or more of fittings can be tested. If any of the tested fittings fail, then testing should be expanded to include a higher percentage of fittings.
LOW	TBD	TBD	A responsible authority should determine what level, if any, pull testing is required.
MOORING ANCHORS	During installation	100%	All anchors are pull tested during initial installation.

SECTION 3 QUALIFICATIONS

3-1 Personnel. If contracted, the testing of mooring hardware should be conducted under the direct supervision of a Registered Professional Engineer (P.E.) who has experience in the design and inspection of marine structures. At a minimum the supervising engineer (P.E.) should be on site and involved in the testing to assess

and record conditions encountered using standard engineering practice. All rules governing workplace safety should apply.

SECTION 4 BACKGROUND

4-1 General. An understanding of the following information regarding the testing of mooring hardware is essential. Each test will consider the following:

- Orientation: The position (x, y, z coordinates) of the hardware should be based on the coordinate system established during the mooring hardware inspection. Direction of forces applied should be established and recorded utilizing the same coordinate system.
- Magnitude: The load applied to the hardware should be 110% of its rated load capacity. The rated load capacity of the hardware can be gathered from existing data.
- Duration: The duration that test loads are applied should be dependent upon the level of the test, and the discretion of the supervising engineer (P.E.).

4-2 Load Path. The load path followed by the mooring line load through the fitting into the supporting concrete slab is essentially the same for all the mooring fittings.

The mooring line load is applied under the horn or lip at the mooring post. The upward vertical load component from the mooring line causes a vertical shear at the base of the horn or lip for loads with nonzero vertical load components. The horizontal load component at the load point induces shear stresses in the cross section of the mooring post. The upward tensile force causes tensile stress in the cross section of the mooring post as well as a constant bending moment along the mooring post axis about a horizontal axis normal to the load. The horizontal load component induces a bending moment that increases with distance from the load point toward the base of the mooring post. This bending moment is a maximum at the base of the mooring post.

The axial and shear forces and bending moments at the base of the mooring post are resisted by the base plate through flexure and shear action. At the bottom of the base plate, the resulting forces and moments are resisted by the tensile and shear stresses in the anchor bolts. However, a small portion of these forces and moments is resisted by friction between the toe of the base plate and the concrete and by bearing of the vertical sides of the base plate against the adjacent concrete. The shear and tensile forces in the anchor bolts are resisted by the concrete base through bearing, shear and tensile stresses in the slab. The concrete slab transfers these loads from the anchor bolts to the pile cap through shear and tensile stresses and then to the support piles. In turn, the piles transfer the forces to the supporting soil.

4-2.1 Load Failure. The failure of any component along the load path described above from the load point to the ground disrupts the flow of forces unless there are sufficiently strong adjacent parallel load paths to take up the load carried by the failed component. A disruption of the load path can lead to the failure of the load resisting system as a whole."

4-3 Supporting Structures. Consideration of the supporting structure is a critical component of planning a hardware test. Personnel responsible for carrying out the testing program must determine the following:

- The structural adequacy of the system to support the test load.
- General condition of the supporting structure.

Once it is determined that the supporting structure was designed to handle the fitting and the condition of the structure is sound, the test can be carried out.

4-4 Failure Modes. There are various modes of failure associated with mooring hardware. In most cases of failure under in-service conditions occur in the fasteners. When the fitting is embedded in concrete and does not utilize a bolted connection the fitting will generally fail by cracking in areas of high tensile stress or excessive bearing stress. It has been observed that some failures of mooring hardware do not result from mooring line loads. These failures result from overload due to vehicular impact, cranes accidentally setting loads upon the fitting, and other miscellaneous incidents. This type of failure should be observed prior to conducting a load test and should be grounds to abort the test. Mooring hardware with obvious distress should be taken out of service immediately.

Failure under load test is generally associated with corrosion of the fasteners or failure of the supporting structure. The following methods should be used for detection of failure:

- Visual observation of distress or movement.
- Measured permanent yielding or displacement following release of test loads.
- Observation of cracking.

SECTION 5. METHODS

5-1 General. The purpose of a hardware test is to ensure that mooring hardware is capable of holding its design load. Several general methods exist to test fittings:

5-1.1 Pull Testing. There are four methods of pull testing:

- Pull test with a test rig, which may include jacking equipment.
- Pull test with a land based crane or winch.
- Pull test with a water based crane or winch.
- Pull test similar mooring hardware one-against-the-other to test two pieces of mooring hardware at once using hoisting equipment to apply the load. Note: If fitting fails, take out of service immediately and replace or repair as soon as possible.

5-1.2 Bolt Testing. Bolts transmit the load to the structure and are often the critical component in many fittings. Therefore, consider testing the bolts in lieu of testing the entire hardware. Bolts act in tension and shear to resist loads applied to mooring hardware. Since most hardware is set in a grout or concrete base and have

shear keys integral with the fitting, most of the shear stresses are resisted by the concrete or grout base. This is not the case on structures constructed of timber or steel where all loads are resisted by the fasteners. If the fitting is set in concrete, the fasteners need only to be tested in tension. In cases such as timber structures or steel structures, the fasteners are readily accessible and can be removed for inspection, eliminating the need to load test. Bolts that have their anchorage in concrete should be load tested in tension using the procedures outlined in ASTM E 488, *Standard Test Methods for Strength of Anchors in Concrete and Masonry Elements*. It should be noted that tension and testing of fasteners will not provide a comprehensive indication of load capacity of the system.

The bolt testing procedure is:

- Remove the grout and nuts from the bolts.
- Pull-test each bolt to 110% of its working load using a pull test rig. The pull test procedure should follow the procedure for testing anchors described in ASTM E 488, *Standards Test Methods for Strength of Anchors in Concrete and Masonry Elements*.
- If test is successful, reinstall the nuts and grout to the design condition.
- If bolt fails, take out of service and replace as soon as possible.

5-2 Results. Load testing results are reported on the form provided in Figure B-1. Remove any mooring hardware that does not pass the pull test and plan and allocate resources for appropriate replacement.

5-3 Levels of Load Testing

- Level 1. Bolt pull test (tension). Bolts are tested individually to determine tensile strength of the bolt and anchorage.
- Level 2. Indirect line load. Hardware pull-tested with actual line force but not in actual direction of mooring line due to cost and convenience, e.g., bollard-to-bollard pull. This level of testing will confirm the strength of the mooring hardware system including the casting, fasteners, and structure.
- Level 3. Load applied in actual direction of mooring line force. This will confirm the working load of the entire system including base structure, anchor bolts and fitting.

5-4 Testing Procedure

5-4.1 Test Prerequisites. Area adjacent to fitting to be tested should be open and clear of vehicles, vessels, or other equipment and associated personnel.

5-4.1.1 Prior to testing, a review should be conducted of the test equipment by qualified personnel to determine its adequacy for the loads to be applied.

Figure B-1. Example Deck Fitting Load Test Report

<u>DECK FITTING LOAD TEST REPORT</u>		Fitting No.: _____
<u>Pre-Test Condition:</u>		
<u>Casting</u>	<u>Anchor Bolts</u>	<u>Concrete Foundation</u>
<u>Size:</u>	<u>Size:</u>	<u>Geometry:</u> _____ (dim., ht. Above grd.)
<u>Type :</u>	<u>Type :</u>	
<u>Condition :</u> (paint, rust)	<u>Condition :</u> (lead fill, paint, rust)	<u>Condition :</u> (cracks, spalls, stains)
_____	_____	_____
_____	_____	_____
Distress : (cracks, abrasions)		

Description of Testing Method _____ Pull Test ___ Bolt Test		
Fitting Position : (with respect to reference point)		
Pre-Test Coordinates		Post-Test Coordinates
X = _____		X = _____
Y = _____		Y = _____
Z = _____		Z = _____
TEST DATE : _____		TEST LOAD : _____
Test Time : Start _____ Finish _____		TEST ANGLE : _____
RESULTS : (Record any manifestation of distress observed, change to cracks in foundation, rust flakes shed, foundation movement, fitting rotation, distortion, fastener yield, etc.)		
Test Director: _____		Date: _____

5-4.1.3 Fittings should not exhibit outward signs of distress or failure prior to conducting a load test.

5-4.2 Test Preparation - General

5-4.2.1 Testing personnel should provide test jigs, jacks, pumps, wire rope rigging, chain falls and dynamometer, as required to perform the test

5-4.2.2 Precautionary measures should be taken to prevent damage to the fitting, dock structure, or fender system. Wood blocks, sheet copper, etc. should be provided to prevent chafing and rope burns as necessary.

5-4.2.3 Monitoring points should be established on the fitting or fastener to track movement under load. Movement should be recorded in the three principal axes. A reference point independent of the fitting or fastener and its foundation should be established to find movement. Surveying methods can be employed to track movement from a safe distance. A target could be affixed to the fitting and readings taken (x, y, z) during the test.

5-4.2.4 The strip of concrete surrounding the base plate of each fitting and the surface of the free edge of the concrete in front of the fitting must be visually inspected for shear cracks. To aid detection of potential shear cracks, it is recommended that an approximately 0.3 meters (1 foot) wide strip surrounding the base plate and the surface of the free edge of the concrete in front of the fitting, be painted with white wash or light colored brittle paint.

5-4.3 Test Precautions

5-4.3.1. \1\ Accomplish all work operations in accordance with the standards identified in Appendix A. Provide U.S. Coast Guard (USCG) approved life jackets or buoyant work vests to employees working over or near water, where the danger of falling into the water and/or drowning exists. Encourage employees to utilize such equipment. Evaluate the requirement for the use of personal floatation devices (PFDs) on piers, taking into consideration falling/tripping hazards, proximity to edge, obstacles/obstructions, availability and placement of life rings with lines, access ladders, etc. /1/

5-4.3.2 Provisions should be made for keeping personnel not involved in the test clear of the test site and any danger areas.

5-4.4 Test Procedure

5-4.4.1 Using the test jig, chain falls, dynamometer, etc. and a wire rope pendant, exert a horizontal pull equivalent to 110% of the rated working load for the test fitting or fastener. Application of the load should be 100 mm (4 inches) below the lip, horn, or other line holding device on fittings. The load should be held for 10 minutes. At the end of 10 minutes, the fitting or fastener should be examined for any evidence of failure. The results should be recorded on the load test record sheet.

SECTION 6 REPORTING

All results of testing should be recorded on the deck fitting load test record shown in Figure B-1. These records should be included in the baseline report prepared under Section 5 of this document.